

Coupled Shades System with Fascia
SUNTECHRS16 Clutches Lift up to 16 lbs.
SUNTECHRS24 Clutches Lift up to 24 lbs.

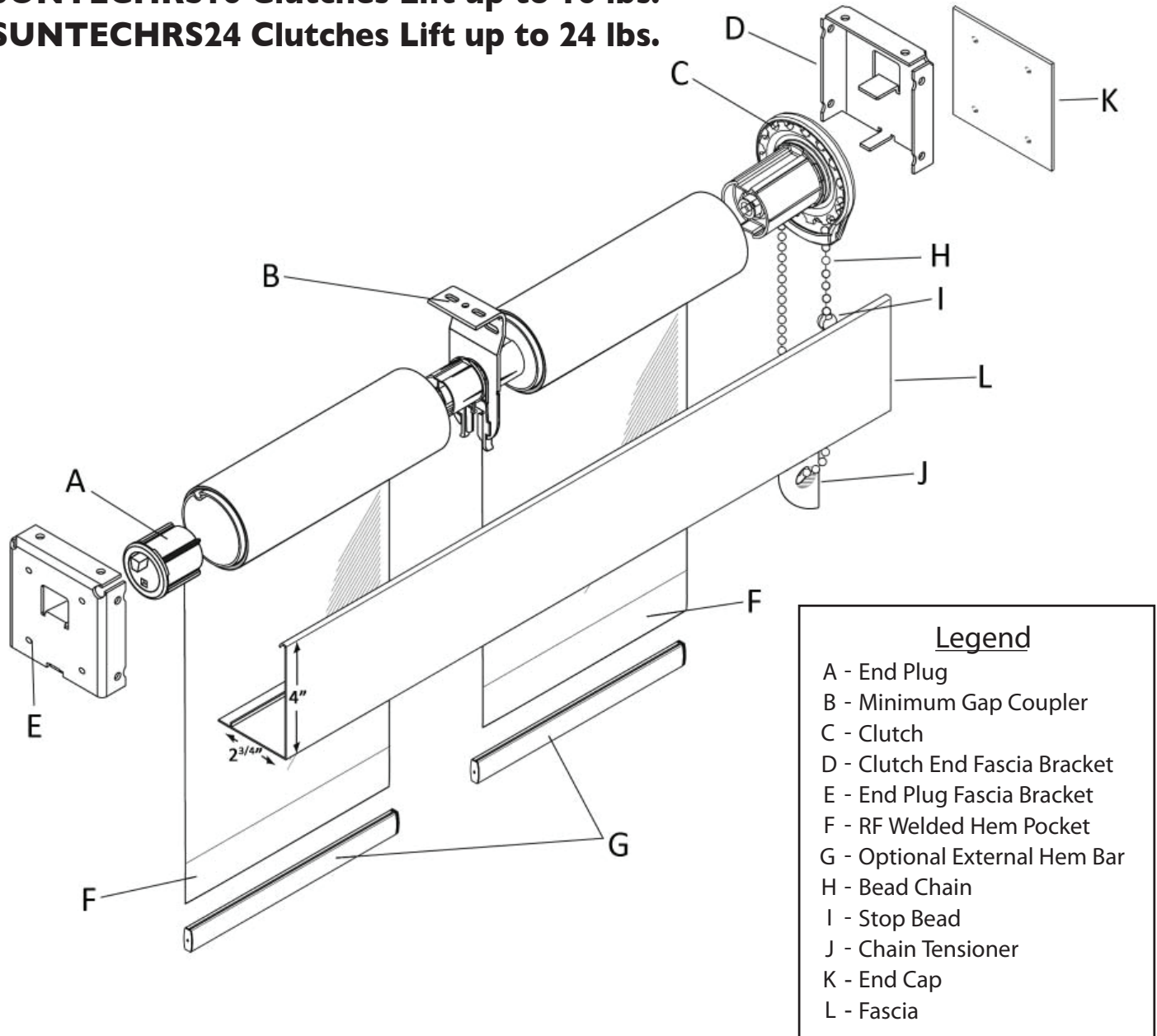

| Legend | |
|--------|---------------------------|
| A | End Plug |
| B | Minimum Gap Coupler |
| C | Clutch |
| D | Clutch End Fascia Bracket |
| E | End Plug Fascia Bracket |
| F | RF Welded Hem Pocket |
| G | Optional External Hem Bar |
| H | Bead Chain |
| I | Stop Bead |
| J | Chain Tensioner |
| K | End Cap |
| L | Fascia |

- ☼ Two or more individual shades can be connected and operated by a single clutch mechanism. Available with ST-16 and ST-24 Clutch Lift Systems.
- ☼ Adjustable leveling screw allows for precise leveling of shades.
- ☼ The number of shade bands is based on shade size and fabric selection.
- ☼ Fascia measures 4" high with a 2-3/4" bottom lip and snaps onto a 4" x 4" fascia bracket.
- ☼ Optional spring assist or geared clutch reduces pull force allowing easy lifting of larger shades.
- ☼ Motorized options available